

RIVETING  
MACHINE

# HYDROPNEUMATIC RIVETE RIV508

Ref. 055407

With a force of 21 000 N, the hydropneumatic riveting machine RIV 508 is the ideal tool for installing «POP» blind rivets (4.8 mm to 7.8 mm).

## RIV 508

- For installing «POP» blind rivets
- Maximum force 21 000 N.
- Ergonomic handle.
- Maintenance free.
- Delivered with riveting kit  
Ø 4.8 to 7.8 mm.

## DIMENSIONS

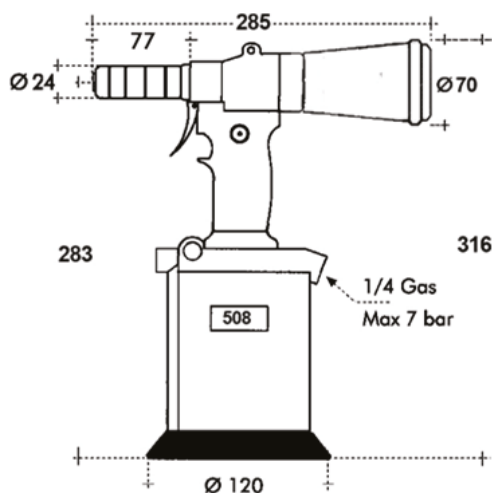

## INCLUDES

**KIT** : for rivet installation  
POP Ø 4.8 to 7.8 mm.



## CARRYING CASE



Air pressure	Air pressure min>max	Air consumption/cycle (6 bar)	Stroke	Max. power (6 bar)		Vibration	Noise level
6 bar	5>7 bar	4.9 lt	21 mm	21 000 N	2.3 kg	< 2.5 m/s <sup>2</sup>	78.5 dB (A)